

Lincoln 72

Typo
Specialissimo



Original drawing by Roland Hirter, 1972.



Original drawings by Roland Hirter, 1972.

Design

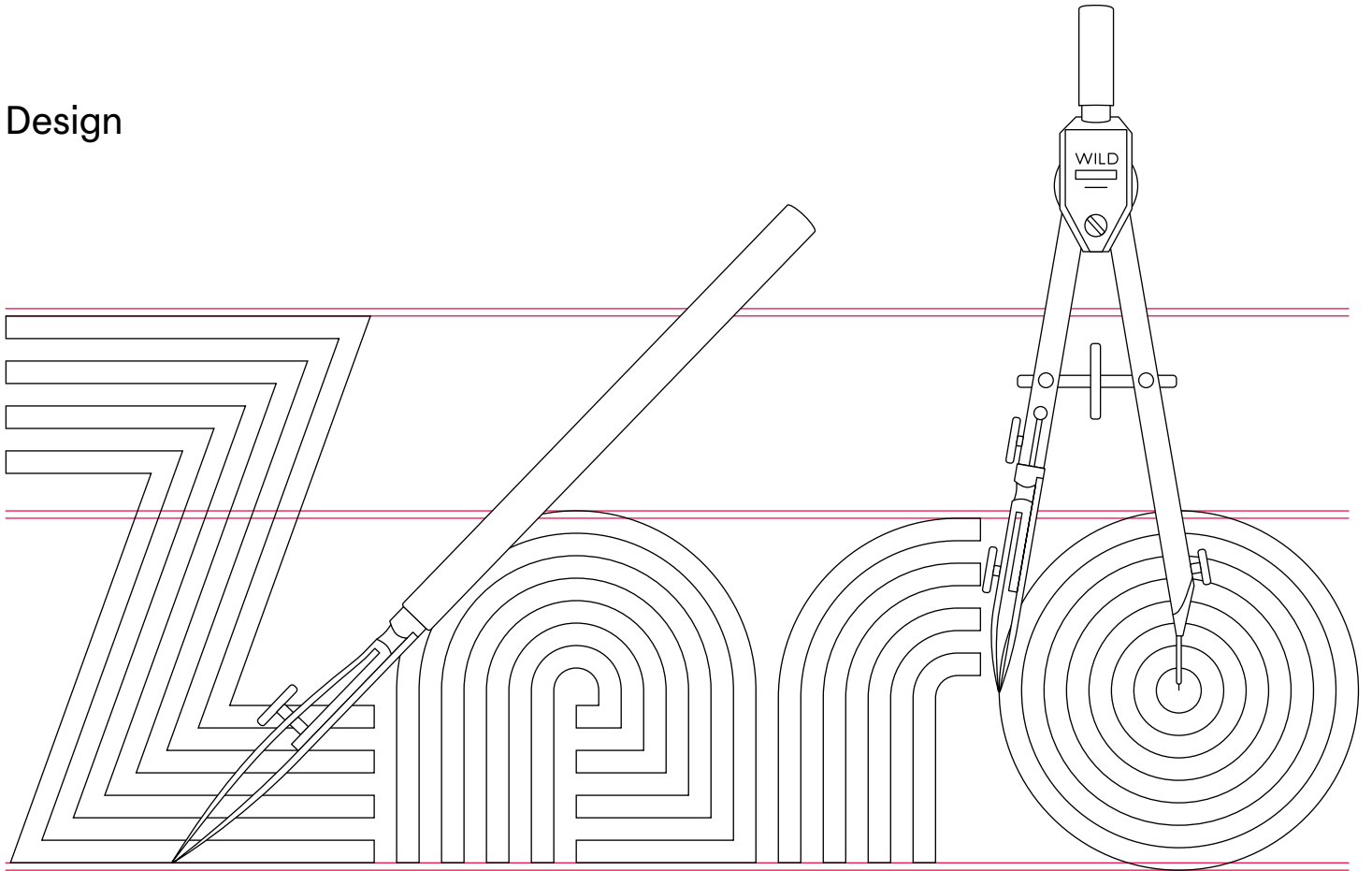

Available Styles

Linea 72 Regular

Regular

Linea 72 Kontur

Kontur

About Linea 72

Linea 72 was designed by Roland Hirter back in the phototypesetting days, when typefaces were really drawn by hand. It was a static environment, where each work step took its time. With the decision to digitize the typeface, we chose to do it from a today's point of view. That's why the font now includes ten stylistic sets, offering a wide range of opportunities for several glyphs. For now it comes in the two original styles Regular and Kontur.

Technical Information & Contact

Fontset

684 Glyphs, Basic Latin (ASCII),
Latin-1 Supplement (ISO/IEC 8859-1)

Language Support

Albanian, Basque, Bosnian, Breton, Chamorro, Chichewa, Croatian, Czech, Danish, Dutch, English, Estonian, Faroese, Finnish, French, Frisian, Galician, German, Italian, Latvian, Lithuanian, Maltese, Norwegian, Polish, Portuguese, Romanian, Romansh, Slovak, Slovenian, Spanish, Swedish, Turkish, Welsh

File Formats

Print: otf
Web: woff, woff2

Release

Version 1.005, February 2023

Distribution

www.olof.ch

Design

Roland Hirter, 1972 / Thomas Hirter, 2022

Contact

Thomas Hirter, Grafiker
Mattenhofstrasse 5
CH-3007 Bern
Switzerland
www.olof.ch
type@olof.ch

Open Type Features

Stylistic Set 01, Legacy (Original drawing 1972)

A B C D E F G H I J K L M N O P Q R S T U
 V W X Y Z æ œ
 a b c d e f g h i j k l m n o p q
 r s t u v w x y z ñ ò ú
 0 1 2 3 4 5 6 7 8 9

Stylistic Set 06, Square Capitals

À Á Â Ã Ä Å Æ Ç È É
 Ê Ë Ì Í Î Ï Ñ Ò Ó
 Ô Õ Ö × Ø Ù Ú Û Ü

Stylistic Set 02, 45°

À Á Â Ã Ä Å Æ Ç È É
 Ê Ë Ì Í Î Ï Ñ Ò Ó
 Ô Õ Ö × Ø Ù Ú Û Ü

Stylistic Set 07, Pointy Diagonals

À Á Â Ã Ä Å Æ Ç È É
 Ê Ë Ì Í Î Ï Ñ Ò Ó
 Ô Õ Ö × Ø Ù Ú Û Ü

Stylistic Set 03, 90°

À Á Â Ã Ä Å Æ Ç È É
 Ê Ë Ì Í Î Ï Ñ Ò Ó
 Ô Õ Ö × Ø Ù Ú Û Ü

Stylistic Set 08, Futuristic

À Á Â Ã Ä Å Æ Ç È É
 Ê Ë Ì Í Î Ï Ñ Ò Ó
 Ô Õ Ö × Ø Ù Ú Û Ü

Stylistic Set 04, Circular Punctuation

À Á Â Ã Ä Å Æ Ç È É
 Ê Ë Ì Í Î Ï Ñ Ò Ó
 Ô Õ Ö × Ø Ù Ú Û Ü

Stylistic Set 09, Merged Lines

À Á Â Ã Ä Å Æ Ç È É
 Ê Ë Ì Í Î Ï Ñ Ò Ó
 Ô Õ Ö × Ø Ù Ú Û Ü

Stylistic Set 05, Thin Punctuation

À Á Â Ã Ä Å Æ Ç È É
 Ê Ë Ì Í Î Ï Ñ Ò Ó
 Ô Õ Ö × Ø Ù Ú Û Ü

Linea 72 Regular

220 pt (ss06)

W H O T E L

170 pt

C A P I T O L

128 pt (ss02)

C l u b S t y l e

62 pt (ss04, ss08)

ß U E ß B ä i r g z ä n t r u m

38 pt (ss05)

ß u b a n b e r g / C a m e r a / C l u b / M o v i e

Linea 72 Kontur

210 pt

Z z i h k m l

124 pt (ss03)

G E O M E T R Y

132 pt (ss03, ss04)

R r i s s r k d l r

92 pt

d r a w i n g t o o l s

56 pt

p r o t e i l a n d i i n k o n p a p e r